

STREETEC autoleveling

Air Suspension Control System

English



AN 1010 - EN - R1.0

STREETEC autoleveling

Air Suspension Control System

English

Installation instructions

Version AN 1010 - EN - R1.0

Foreword



Dear Customer,

Congratulations on purchasing your STREETEC autoleveling device. Please read the following instructions carefully and follow them to prevent potential damage. We assume no liability for damage caused by disregarding these instructions or improper use. Scan the QR code to access the latest operating instructions and further information about the product.

Contents

8	Safety instructions
9	General information
10	ECU
14	Touchscreen (HMI)
18	Valve 4
22	Water Separator
26	Pressure Sensors
30	Height Sensors
40	Harness Installation
46	Connection Diagram
48	Installation of Air Lines
50	Assembly of Air Line / Fitting
51	Dismantling Air Line / Fitting
52	autoleveling APP
54	Quick Start Guide
66	Settings
78	Firmware Update
79	Guarantee
80	Declaration of conformity
81	Disposal instructions
82	Manufacturer information

Safety instructions

- Never install the STREETEC autoreleveling control with the ignition on. Ensure the ignition key is removed. Wait at least 5 minutes after turning off the ignition until all electrical devices are completely deactivated.
- Route cables and hoses so they don't touch or chafe against moving or metal components. Improper fastening can lead to malfunctions, which will void the manufacturer's warranty.
- Wear appropriate personal protective equipment during installation to avoid injuries.
- Manipulation of the product, especially the housing, is not permitted.
- Any unauthorized modification will void the manufacturer's warranty. Work on the vehicle's electrical and pneumatic components, as well as on the STREETEC autoreleveling control system, may only be performed by qualified personnel.
- Keep the housing and all components of the control unit as dry and free from dirt as possible to ensure proper function.
- Make sure that all pneumatic and electrical parameters comply with the specifications.

General information

The STREETEC autoleveling system is used to adjust the vehicle height in vehicles with aftermarket air suspension systems. This manual provides important information on using the STREETEC autoleveling system. Adhering to all safety instructions and operating instructions is a prerequisite for safe operation. Read these instructions carefully before installation to ensure you can fully enjoy the system's technical benefits. Only install the system after you have read and understood these installation guidelines. We recommend that you have it installed by a specialist workshop. The STREETEC autoleveling system was developed and produced with great care. Therefore, it should also be installed with care. By following the instructions provided, you will prevent the warranty from being voided prematurely and you will enjoy your product for years to come. Note: Use the STREETEC autoleveling system exclusively for aftermarket air suspension systems. In the event of a defect, do not attempt to repair the device yourself. Leave this to the manufacturer.

ECU

The STREETEC autoleveling ECU consists of a high-quality aluminum housing with a high-gloss acrylic cover. We recommend handling the ECU carefully during installation to avoid impairing its optical properties.

The ECU has been designed to be mounted in the vehicle in several ways:
Lying flat with fully hidden wiring or bolted to a bracket (a bracket is included in delivery to allow the ECU to be mounted upright).

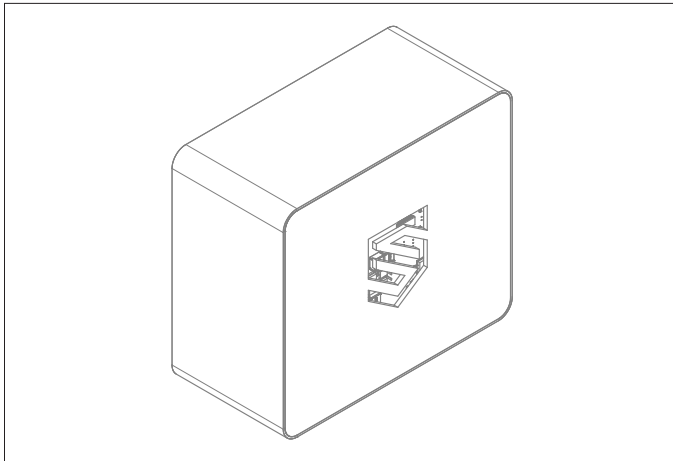

Fig. 1: STREETEC autoleveling - ECU

ECU



The ECU must be securely bolted to the vehicle. Otherwise, calibration may not be performed accurately, and control problems may occur!

1. Select a mounting location for the component. The mounting location should be dry and allow the ECU to be securely mounted.
2. Check whether you can route the wiring harnesses to the intended location.
3. Use the supplied drilling template to drill the holes if the ECU is to be mounted flat.
4. Connect the wiring harnesses before attaching the ECU. This will make the job a little easier.
5. Then attach the ECU directly to a surface or to the bracket.



Included in delivery is a drilling template for easy positioning and installation of the ECU!

Technical Data - ECU

Product details

product	STREETEC autoleveling - ECU
Item number	2013 0 0004
Dimensions (L x W x H)	124.5 mm x 107.5 mm x 60.5 mm
Weight	363 g

Electrical details

Power (standby)	2W
Power (valve switched)	50W
Nominal voltage	12V DC
max. current	5A

Dimensions - ECU

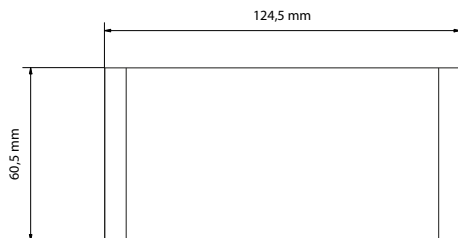
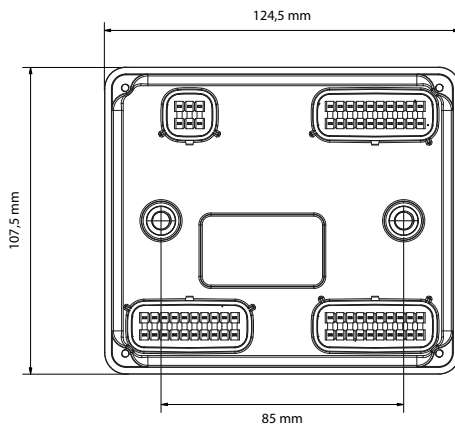
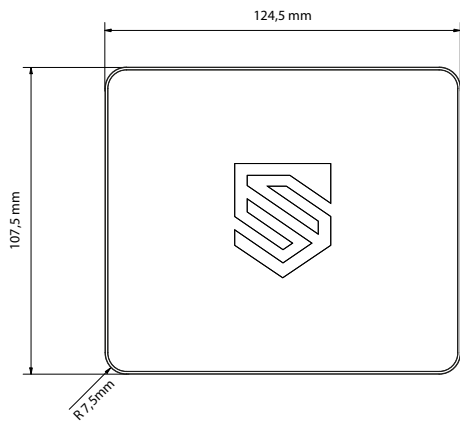

Touchscreen

The STREETEC autoleveling touchscreen (HMI) consists of a high-quality aluminum housing with integrated neodymium magnets. We recommend handling the touchscreen carefully to avoid damaging its optical properties.

Thanks to the integrated magnets, the control unit can be easily attached to all magnetic surfaces in the vehicle.

The touchscreen has a USB-C port for connecting to the wiring harness.

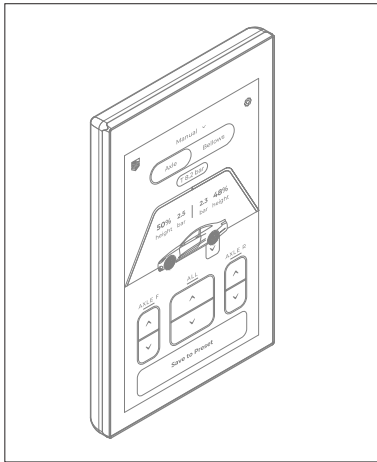

Fig. 1: STREETEC autoleveling - touchscreen

Touchscreen

The STREETEC autoleveling touchscreen features numerous technical innovations that give the system a special value.

The capacitive touchscreen works on the same principle as a smartphone. Commands are executed exclusively by touch, without pressure.

The system supports multi-touch mode, which allows different functions to be used simultaneously or in combination.

Haptic feedback gives the feeling of pressing real keys.

For better visibility when driving at night, the display can be automatically dimmed when the headlights are switched on.

The user interface can be individually configured for up to three different users.

Technical Data - Touchscreen

Product details

product	STREETEC autoleveling - Touch Pad
Item number	2013 0 0003
Dimensions (L x W x H)	114.5 mm x 71 mm x 10.2 mm
Weight	135 g

Electrical details

Nominal voltage	5V DC
max. current	500 mA

Dimensions - Touchscreen

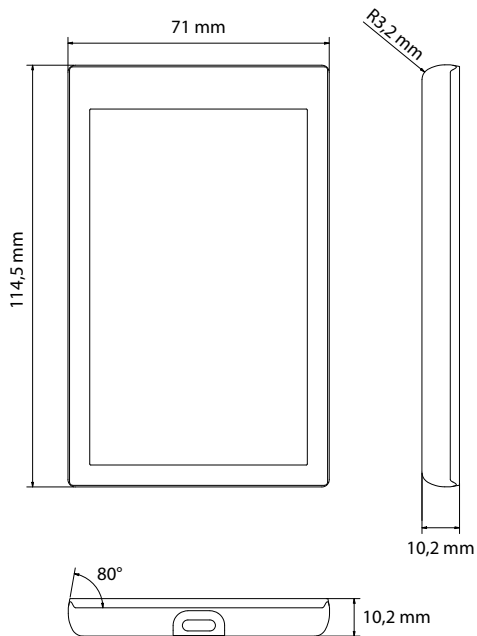

Valve4

The STREETEC valve4 valve block was developed for clean installation and maximum reliability.

The valve4 can fill and vent four compressed air circuits and is equipped with G 1/4" connections. It is designed for maximum flow, pressures up to 14 bar, and a long service life with millions of switching cycles.

Thanks to its compact design with an overall size of approx. 125 x 55 x 80 mm, the valve block is ideal for all air suspension systems.

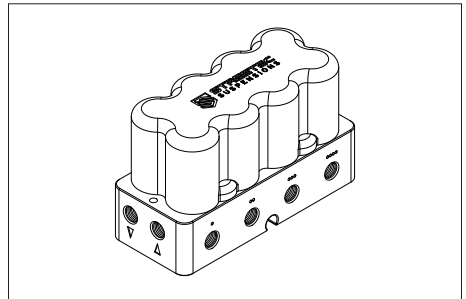

Fig. 2: STREETEC valve4



The recommended installation of the valve4 valve block takes place in the interior of the vehicle.

If the valve block is to be installed outside the interior, a location must be chosen that is protected from splash water and moisture.

1. Decide which direction you want to route the cable out of the valve block. By removing the base plate (Fig. 3), the cable can be positioned and secured accordingly (Fig. 4).

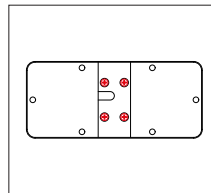

Fig. 3: Base plate

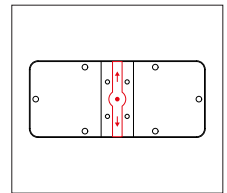

Fig. 4: Cable routing

Valve4

2. Position the valve4 at the desired installation location. Ensure that the valve4 valve block can be securely fixed in the selected location.
3. Secure the valve block using the included mounting kit. If the mounting surface is uneven, add



Do not install the valve4 upside down! Proper installation of the valve block prevents water from accumulating in frost-sensitive areas. If installed incorrectly, proper function of the STREETEC autoreleving system cannot be guaranteed.

washers or a spacer to level the surface (Fig. 5). In this case, additional mounting screws may be required.

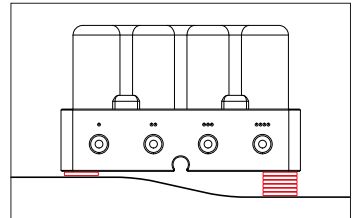

Fig. 5: Compensation mounting surface



Included in delivery is a drilling template for easy positioning and assembly of the valve4 valve block!

Technical Data - Valve4

Product details

product	STREETEC autoleveling - valve4
Item number	9909 2 0204
Dimensions (L x W x H)	52 mm x 123 mm x 75 mm
Weight	1150 g

Electrical details

Power (standby)	0W
Power (valve switched)	12W per solenoid valve
Nominal voltage	12V DC
max. current	1A per solenoid valve

Pneumatic details

Operating pressure	max. 12 bar
--------------------	-------------

Dimensions - Valve4

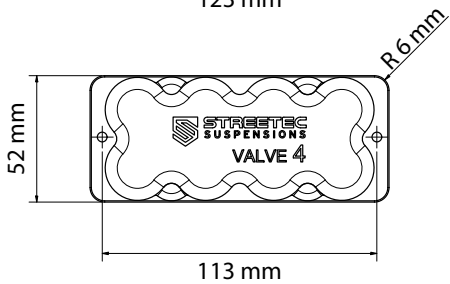
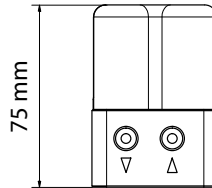
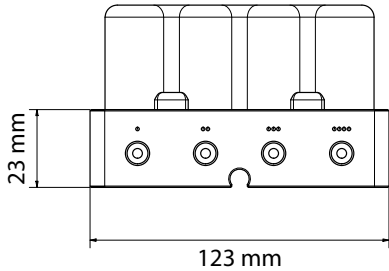

Water Separator

The compressors in the air generation kit absorb moisture from the outside air. This moisture then enters the air tank, where it settles. The STREETEC autoleveling system is supplied with a water separator that significantly reduces this moisture in the system and protects it from corrosion and moisture damage. This also minimizes the risk of moisture entering the valve block.



The tanks must still be vented regularly to eliminate the risk of residual moisture in the system! To do this, please install the tank's vent valve with a hose leading from the vehicle interior to prevent moisture damage to other components caused by the tank's venting. If this isn't possible, place a highly absorbent material (e.g., a microfiber cloth) under the vent valve opening.

Please note the following installation guidelines:

1. Install the water separator in the correct flow direction. The arrow on the water separator indicates the flow direction and must point from the tank to the valve block (Fig. 1). If you choose not to mount the filter directly on the tank, route the required hose from the tank to the water separator and the hose from the water separator to the valve block with the appropriate connectors.
2. The water separator used in this system is a manually vented water separator and must be emptied regularly.

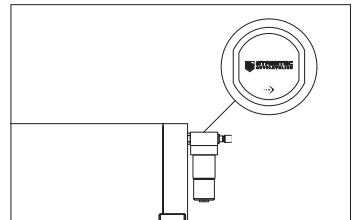

Fig. 1: Flow direction

Water Separator

This ensures that the drying system always functions properly and that no water enters the system. This prevents component failures, such as the valve block. To vent, use the vent button (Fig. 2) on the underside of the water separator. When venting the water separator, use a small container or a highly absorbent material (e.g., a microfiber cloth) to collect the condensate.

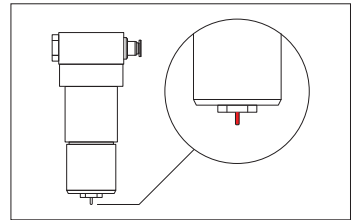

Fig. 2: Vent head

3. Ensure the filter is mounted vertically. Do not install the filter upside down or at an angle (Fig. 3 - 6).

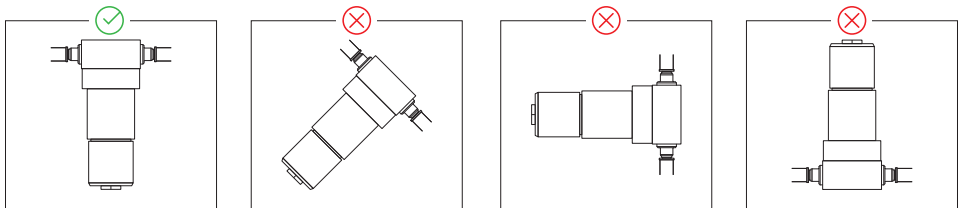

Fig. 3 - 6: Installation position of water separator

Technical Data - Water Separator

Product details

product	STREETEC autoleveling - water separator
Item number	9909 2 0363
Dimensions (L x W x H)	45 mm x 41 mm x 140 mm
Weight	170 g

Pneumatic details

Operating pressure	max. 12 bar
--------------------	-------------

Dimensions - Water Separator

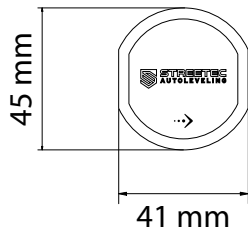
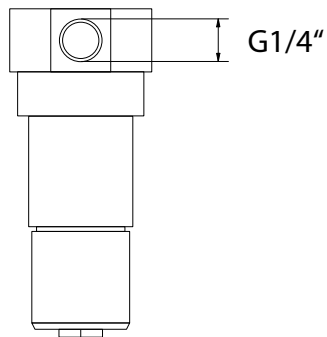
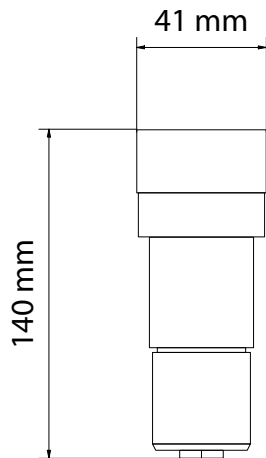

Pressure Sensors

The STREETEC autoleveling pressure sensors are extremely robust sensors for the automotive sector and are designed for a pressure range of 0 to 16 bar. They have a G1/4" thread and are equipped with a seal, so they can be installed without additional sealant. (Fig. 1)

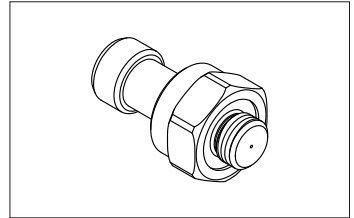

Fig. 1: Pressure sensor

The STREETEC autoleveling comes with 5 pressure sensors:

- 4 sensors for the pressure in the air bellows
- 1 sensor for tank pressure

The sensors for the air bellows can be integrated into the system in various positions:

1. Mounting directly into the valve block (Fig. 2)
2. Installation in the optional pressure sensor block (Fig. 3)
3. Installation in the supply line to the air bellows with optional T-fittings.

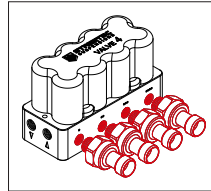

Fig. 2: Valve block

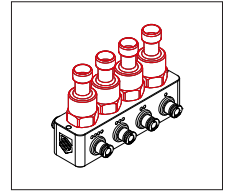

Fig. 3: Pressure sensor block



We do not recommend installing it in the supply line and should only be done in exceptional cases. The T-fittings for installation would have to be purchased separately in this case.

Pressure Sensors

The tank pressure sensor can also be mounted in different ways:

1. Mount directly into the side connection of the valve block (Fig. 4)
2. Installation directly into the air tank (Fig. 5)

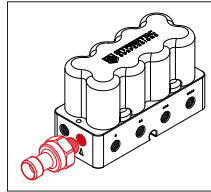

Fig. 4: Valve block

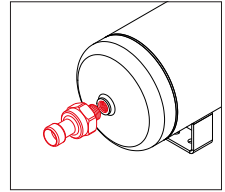

Fig. 5: Air tank



When installing the sensor in the tank, ensure that the pressure sensor is installed near the top of the tank. Also, make sure that the electrical connection on the pressure sensor is not facing downwards (Fig. 5). Otherwise, the sensor may be damaged by condensation in the tank.

3. Hidden mounting on a hose leading away from the air tank or valve block



The assembly on a hose leading from the air tank or valve block We do not recommend this and it should only be done in exceptional cases.

Technical Data - Pressure Sensors

Product details

product	STREETEC autoleveling - pressure sensor PS16-5-1
Item number	9909 2 0504
Dimensions (L x W x H)	51 mm x 28 mm x 28 mm
Weight	44 g

Electrical details

Nominal voltage	5V DC
max. current	30 mA

Pneumatic details

Operating pressure	max. 16 bar
--------------------	-------------

Dimensions - Pressure Sensors

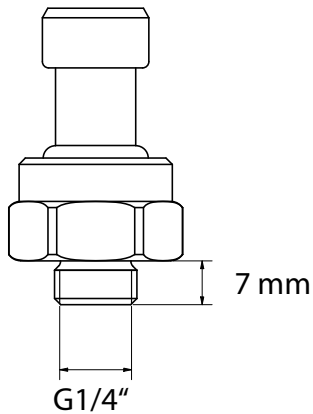
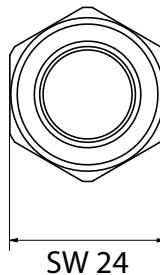
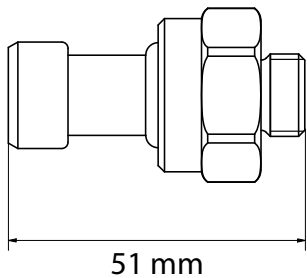

Height Sensors

Installing height sensors (Fig. 1) is complex and requires patience. The goal is to utilize as much of the sensor range as possible to achieve maximum height control accuracy. However, the sensors must always be operated within the approved operating range. (Fig. 2).

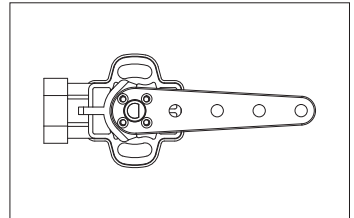

Fig. 1: Altitude sensor

Determine the installation location of the height sensor:

1. Choose a stable attachment point on the body.

The sensor can be mounted in any direction, as long as the sensor arm is in the center position and the flat side of the sensor shaft faces the opposite side of the connector. Height sensors are shipped in position A (Fig. 3). Remove the sensor arm to rotate it to position B (Fig. 4) or C (Fig. 5). If possible, mount the sensor in position A or B so that the arm is opposite or rotated 90 degrees from the connector. If this is not possible, ensure that the connecting cable cannot come into contact with the sensor arm.

2. Try to find a mounting location where the sensor is directly above the potential mounting point of

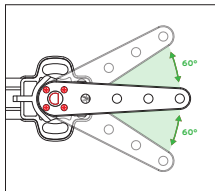

Fig. 2: Work area

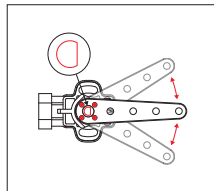

Fig. 3: Position A

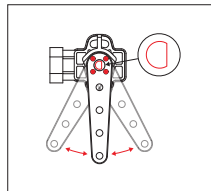

Fig. 4: Position B

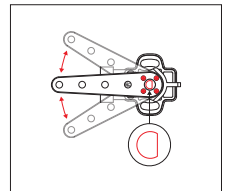

Fig. 5: Position C

Height Sensors



Ideally, mount the sensors in the same location on the driver and passenger sides of the vehicle, mirroring each other. This ensures that the sensor area is as equal as possible on each side.

the height sensor's stabilizer link. This mounting point is usually located on a control arm of the chassis. For most vehicles, it will be necessary to fabricate a bracket to position the sensor and the stabilizer link mounting point correctly.

3. Ensure that the sensor and sensor arm are sufficiently clear of chassis components, wheels, and other moving parts. It's important to ensure this clearance is maintained even when the wheels are fully turned.
4. Also make sure that the sensors and cables are kept far enough away from hot vehicle components.
5. Make sure that the attachment points are suitable for the entire travel range of the chassis/vehicle.
6. Always try to use original mounting points and holes to attach the sensor and coupling rod.



We strongly recommend performing the necessary work on a car lift and using a transmission jack. Using a car jack will make the work significantly more difficult and may not lead to quick results.

Height Sensors

Selecting the sensor position:

1. Attach the sensor to the vehicle and center the sensor arm. Disconnect the air line from the air bellows and raise the suspension using a transmission jack to the lower end stop of the chassis. Measure the distance [A] from the Position the sensor arm to the selected coupling rod attachment point (Fig. 6). Ensure that the attachment points are suitable for the entire travel range of the chassis/vehicle.

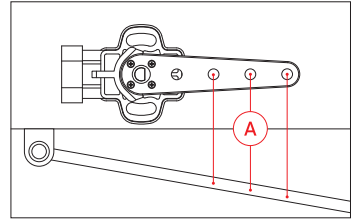

Fig. 6: Coupling rod attachment point

2. Reconnect the air line and apply sufficient air pressure to the air bellows until the chassis is at its upper end stop. Now measure the distance [B] from the sensor arm to the selected coupling rod attachment point again (Fig. 7). The difference between the two measured values gives the maximum travel [C].

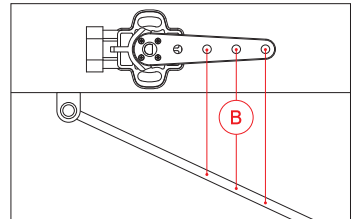

Fig. 7: Coupling rod attachment point

$$C = B - A$$

Height Sensors

Selecting the correct mounting hole for the coupling rod in the sensor arm

The maximum angle for the height sensor is 120 degrees. Selecting the correct mounting hole ensures that this value is not exceeded. Use this table to select the correct mounting hole (Fig. 8).

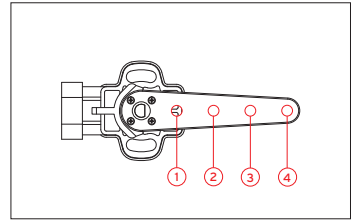

Fig. 8: Mounting holes sensor arm

Hole	min. travel C [mm]	max. travel C [mm]
1	18	30
2	30	52
3	52	80
4	80	120

Height Sensors

Adjusting the length of the coupling rod

1. Using a transmission jack, position the suspension at the center of its travel and the sensor arm at the center of its working range. Now measure the distance [D] between the selected mounting hole and the coupling rod attachment point (Fig. 9).
2. Shorten the coupling rod's threaded rod. The length of the threaded rod must be 40 mm less than the distance measured in point 1 (Fig. 10).
3. Shorten the rubber sleeve on the threaded rod. The length of the rubber sleeve must be 55 mm less than the distance [D] measured at point 1 (Fig. 11).

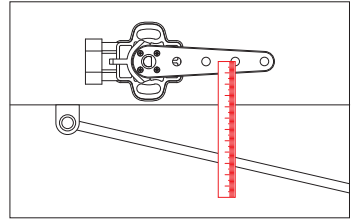

Fig. 9: Sensor arm length

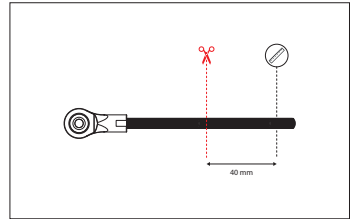

Fig. 10: Shortening the threaded rod

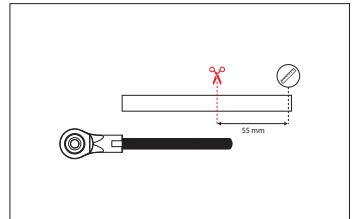

Fig. 11: Sensor arm center position

Height Sensors

4. If you don't have a thread cutter available to deburr the threaded rod, screw a nut onto the threaded rod before cutting it. Use the nut to deburr the rod end (Fig. 12).

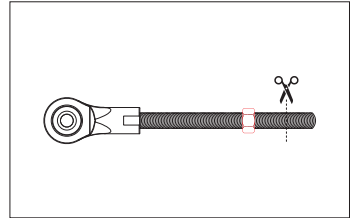

Fig. 12: Marking intersection point

5. Screw the threaded rod into both heads of the coupling rod approximately 10 turns. This will allow you an adjustment range of approximately ± 10 mm in length for any necessary adjustments later. (Fig. 13)

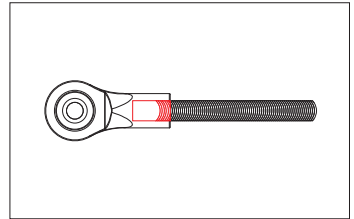

Fig. 13: Screwing in the threaded rod

6. Mount the coupling rod to the sensor arm and the mounting point on the suspension. Pay attention to the angle between the coupling rod and the sensor arm (Fig. 14). This angle must not exceed 15 degrees and can be adjusted by adding spacers to the mounting point.

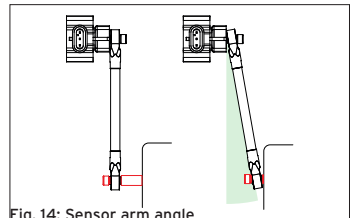

Fig. 14: Sensor arm angle

Height Sensors

Checking the travel path

1. After installing the sensors at all four wheel positions, you can use the sensor tool in the control unit to check the operating range. Proceed carefully to avoid damaging the height sensors. Ideally, you should first perform the tests on a lift using the transmission jack. The maximum voltage range of the sensors in the operating range is between 0.5 and 4.5V. These values must not be exceeded or undershot when the chassis is fully raised or lowered. Otherwise, the position of the sensors, the coupling rods, or the length of the coupling rods must be revised.



Check the travel distance of the height sensors using the sensor tool. You can find it in the installer settings.

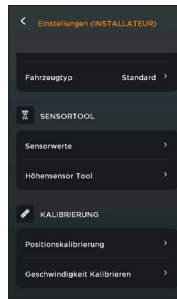
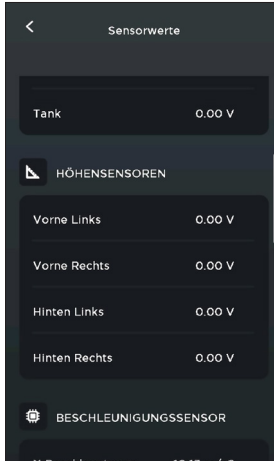
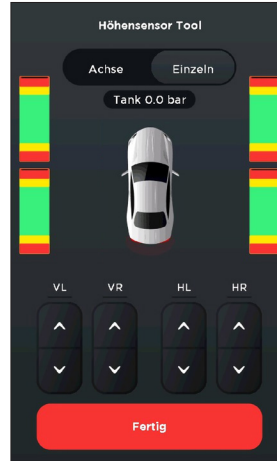

Fig. 1: Installer settings - SENSORTOOL



The "Sensor Values" screen displays the currently measured voltages of the altitude sensors. These are located below the measured values for the pressure sensors.



The height sensor tool allows the chassis to be adjusted manually, while the values of the height sensors are displayed by a black mark in the respective bars.

For a complete check, the chassis must be completely emptied and filled. The yellow zone should not be reached. The red zone must not be reached under any circumstances, as this would put the sensors outside their measuring range.

Technical Data - Height Sensors

Product details

product	STREETEC autoleveling - height sensor 120°
Item number	9909 2 0027
Dimensions (L x W x H)	109mm x 43.3mm x 40.3mm
Weight	44 g

Electrical details

Nominal voltage	5V DC
max. current	30 mA

Dimensions - Height Sensors

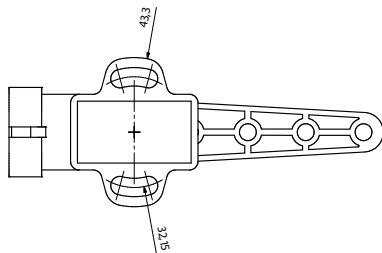
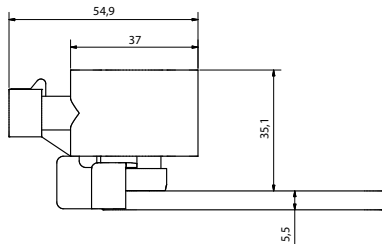
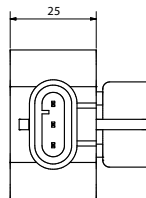
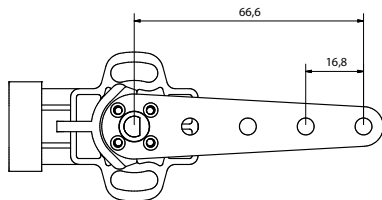

Harness Installation



Disconnect the starter battery before installing the cable harness.

The wiring harness can be installed inside or under the vehicle. In any case, make sure that all parts of the wiring harness are protected from abrasive edges and heat sources.

1. Connecting the AirCU, valve block and compressor

- Connect the wiring harness to the ECU
- Connect the valve block connector to the designated connector on the main wiring harness. Screw the fuse onto the connector.



Remove all fuses from the STREETEC autoleveling system before jump-starting or welding on the vehicle. Failure to do so could damage the system.

- Strip the compressor cables (red/black – 6 mm²) and the counterparts on the main wiring harness (red/black – 6 mm²).
- Connect the stripped compressor wires to the stripped compressor connection wires of the main wiring harness using the supplied heat-shrink connectors.

Harness Installation

2. Connect the wiring harness to the battery and vehicle ground

Battery connection cable (red - 1.5 mm²) for AirCU and valve block

- Strip the cable.
- Strip both cable ends of the smaller fuse holder (1.5 mm²).
- Connect the main wiring harness cable to the fuse holder cable using the supplied heat shrink butt connector.
- Connect the other end of the safety cable to the supplied ring terminal.
- Connect the ring terminal to the positive (+) terminal of the battery.
- Insert the supplied 10 A fuse into the fuse holder, then close the fuse holder cover.

Ground connection cable (black – 1.5 mm²) for ECU and valve block

- Strip the cable.
- Connect the cable to the ring terminal provided.
- Attach the ring terminal to a suitable ground point on the vehicle (follow the manufacturer's specifications).

Battery connection cable (red – 6 mm²) for compressor

Harness Installation

- Strip the cable.
- Strip both cable ends of the supplied fuse holder (6 mm²).
- Connect the main wiring harness cable to the fuse holder cable using the supplied heat shrink butt connector.
- Connect the other end of the safety cable to the supplied ring terminal.
- Connect the ring terminal to the positive (+) terminal of the battery.
- Insert the supplied 40 A fuse into the fuse holder and close the fuse holder cover.

Ground connection cable (black – 6 mm²) for compressor

- Strip the cable.
- Connect the cable to the ring terminal provided.
- Attach the ring terminal to a suitable ground point on the vehicle (follow the manufacturer's specifications).



The included wiring harness can only power a single compressor. Installing two compressors requires a second power cable. Contact a STREETEC dealer to purchase the optional wiring harness for the second compressor (part number: 1160 00 00).

Harness Installation

3. Connecting the wiring harness to the ignition

Connection cable switched plus from the ignition switch (yellow – 0.75 mm²)

- Strip the cable.
- Connect the cable to the pre-assembled butt connector on the blade fuse adapter (yellow cable).
- Remove a fuse of at least 10 A from a wiring harness in the fuse box that carries switched positive from the ignition switch (terminal 15).
- Insert the blade fuse adapter.
- Insert the supplied 10 A fuse and the original fuse in the designated places.



Make sure the cables are laid properly.



Do not use any power source other than switched plus from the ignition switch (terminal 15).

4. Connection of display wiring harness, display & warning buzzer

- Connect the wiring harness to the ECU.
- Route the display wiring harness to the area of the vehicle where you want to use the display.
- Connect the supplied USB-C cable for the display to the designated connector on the display cable harness and the display (bottom) of the STREETEC autoleveling.
- Connect the supplied warning buzzer to the display wiring harness.

5. Height sensor wiring harness connection (optional)

- Connect the wiring harness to the ECU.
- Route and secure the height sensor cables to the respective wheel; the cable shrink labels indicate the positions (FL/VL, FR/VR, RL/HL, RR/HR).
- Connect the height sensor cables to the corresponding connector on the
- Height sensor wiring harness. The positions are also marked on the height sensor wiring harness with shrink labels.

Harness Installation

Make sure that the connection cables are routed to the correct position.

FL / VL	Height sensor on the front left wheel
FR / VR	Height sensor on the front right wheel
RL / HL	Height sensor on the rear left wheel
RR / HR	Height sensor on the rear right wheel



Make sure that the cables routed outside the vehicle are equipped with a drip loop. Otherwise, water could get sucked into the cable connectors!

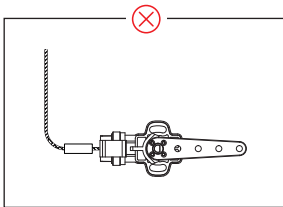
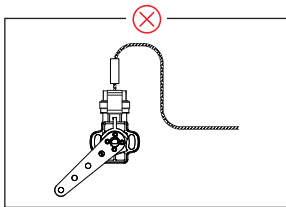
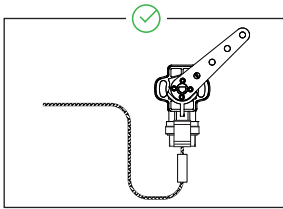
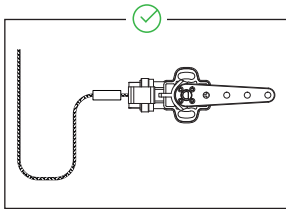

Connection Diagram

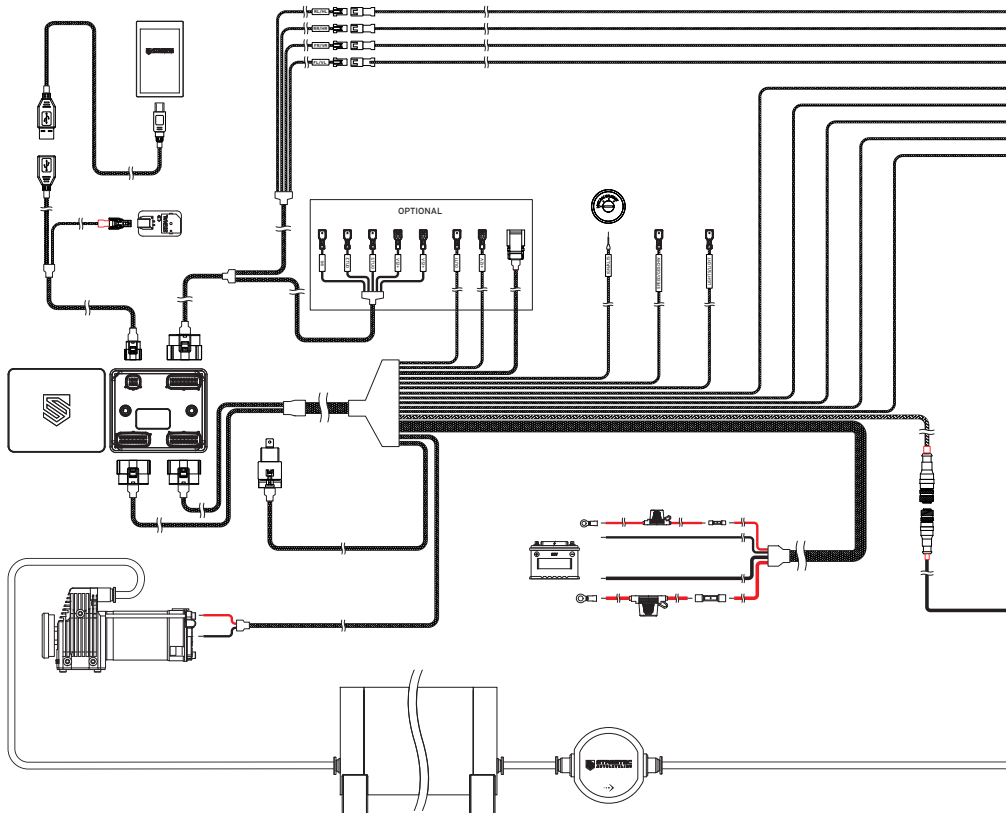

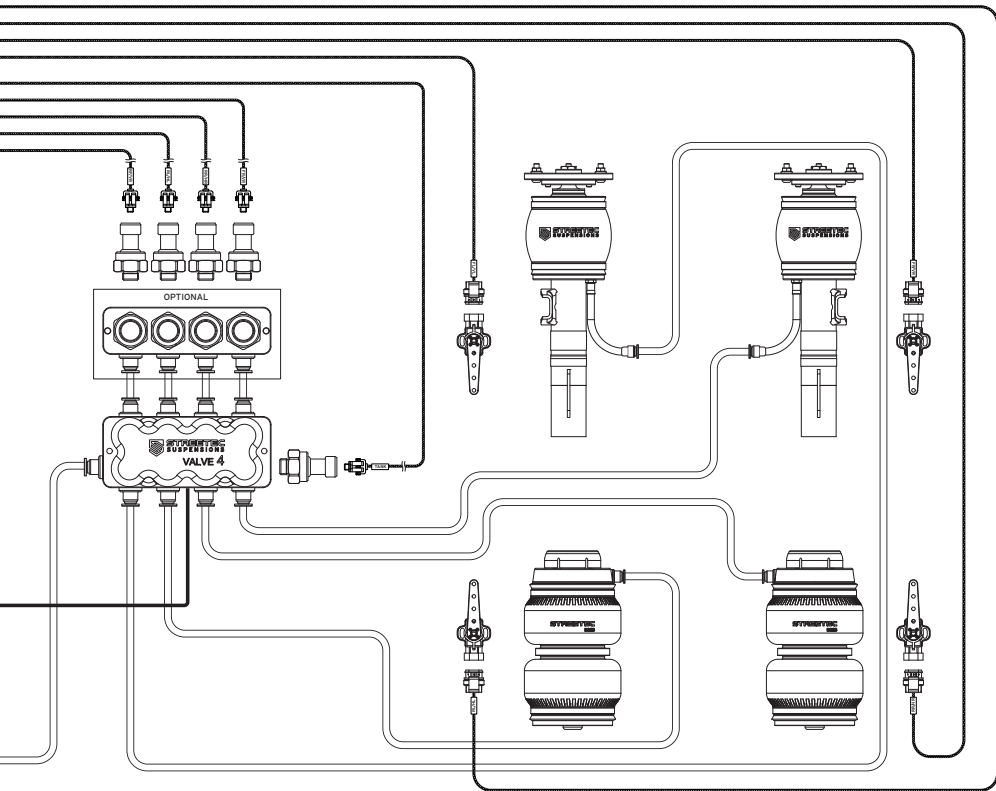

Installation of Air Lines

The air lines can be routed inside or underneath the vehicle. In either case, ensure that all parts of the wiring harness are protected from abrasive edges and heat sources.

1. Route and secure the air lines from the valve block (valve4) to the struts and bellows.
2. Route the line from the valve block to the water separator and from the water separator to the tank if you are not mounting the filter directly on the tank.
3. Screw the supplied silencer into the outlet opening of the valve block.



Lay air ducts free from grinding edges and heat sources.



The air lines should be pushed firmly into the fittings with a slight twist. Check the connection by pulling on each line to ensure a secure connection.

Cutting the air ducts:

- Cut the air duct at right angles to the direction of installation of the air duct
- Check air lines for damage before mounting on the fitting (scratches, tears and crookedness cutting edges)

Installation of Air Lines

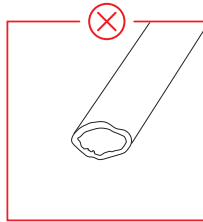
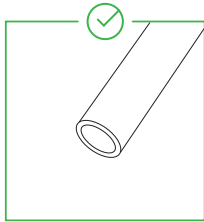

Fig. 1: Cutting surface of the hose

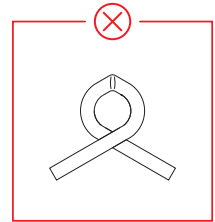
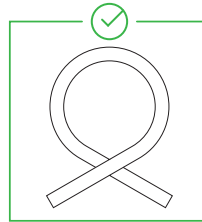

Fig. 2: Bending radius

Tips & Tricks!

Minimum bending radius of the air ducts:

- 6mm air duct – 25 mm bending radius
- 10mm air duct – 55mm bending radius
- 1/4" air line – 30 mm bending radius
- 3/8" air line – 60 mm bending radius

Connecting the air line to a fitting:

- Avoid lateral loads on the hose
- Avoid bends that are closer than 50mm to a fitting.

Assembly of air line / fitting

1. Cut the air duct at a right angle and without burrs. Ensure that the air duct has no sharp edges, longitudinal grooves, or other damage.

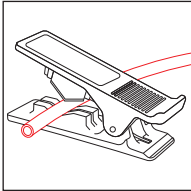

With the included hose cutter (part number: 9909 2 0266) you can create a clean, burr-free and right-angled cutting edge.

2. Push the air line into the fitting until it stops. The retaining element secures the air line in the fitting. The built-in O-ring creates a permanently tight connection.

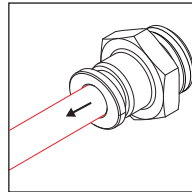
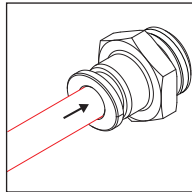
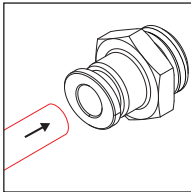

3. Check that the hose is properly inserted. This is easily done by pulling on the air line. This allows you to test the retention function and ensure that no leaks will occur.

Dismantling air line / fitting

1. Make sure the system is depressurized. If it is still pressurized, release it.

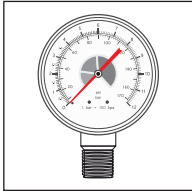

2. Release the pressure from the fitting by pushing the hose in. Push the fitting's retaining element back with your fingers or with the aid of a release tool and hold it in this position.

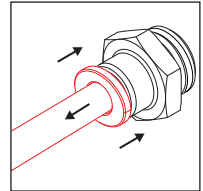
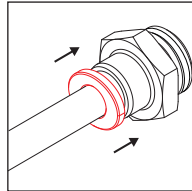

3. The air line can now be removed.

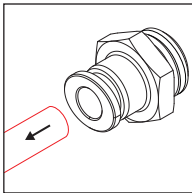

autoleveling APP

Download the free app for the best autoleveling experience.

The STREETEC autoleveling mobile app enables complete integration of your new autoleveling control system with your mobile device. Simply download the free app. to not only take full control of your air suspension, but also to always have the latest firmware with updates directly from the app on your autoleveling.

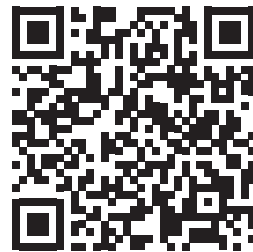

You can also search for “autoleveling” in the Apple App Store or the Google Play Store.



Unit bags

0.1 bar

0.2 bar

0.3 bar

Calibration: Step 3 out of 16

TW · Ride

Axle

Bel lows

T 8.2 bar

50% height

50% height

62% height

FL

FR

RL

RR

Save

TW · Ride

Axle

Bel lows

T 8.2 bar

50% height

62% height

AXLE F

ALL

AXLE R

Save



Ride

Low

High

Manual

Air Out

Level Car

Settings

GENERAL

Pressure Unit

Language

User Profiles

Quick-Access Settings

COMPRESSOR STEERING

Maximum Tank Pressure

Switch Off

psi >

English >

Off >

On >

T2 bar >

TW · Ride

Axle

Bel lows

T 8.2 bar

50% height

62% height

ALL

AXLE R

TW · Manual

Axle

Bel lows

T 8.2 bar

2.8 bar

2.9 bar

AXLE F

ALL

AXLE R

Save to Preset

Manual

Axle

Bel lows

T 8.2 bar

50% height

2.5 bar

50% height

2.5 bar

50% height

2.5 bar

50% height

FL

FR

Ride

T 8.2 bar

3.0 bar

3.0 bar

3.0 bar

Edit Preset

53

New Setup

Start Level

Quick Start Guide

On the following pages we will show you how to use the STREETEC autoleveling and explain the most important functions.

When you first start up the device, you will need to make some basic settings, but these can all be changed later.

Turn on the ignition and let's go!

1



Home screen

Quick Start Guide

2

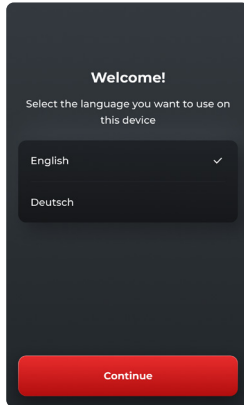

Selecting the language

3

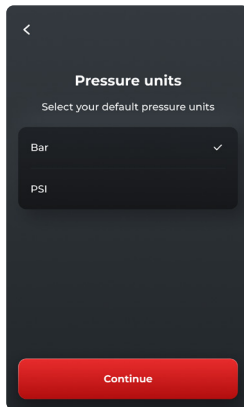

Selecting the unit for the pressure display

Quick Start Guide

4

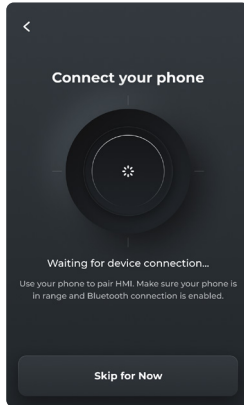

Connection to the smartphone Bluetooth must be activated on the smartphone.

This point can be skipped. → Continue to point 7!

In this case, updating the software via the smartphone is not possible.

Of course, the connection can be made at a later time via the smartphone app.

5

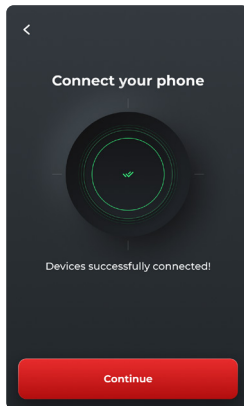

Display when the STREETEC autoleveling has successfully connected to the smartphone.

Quick Start Guide

6

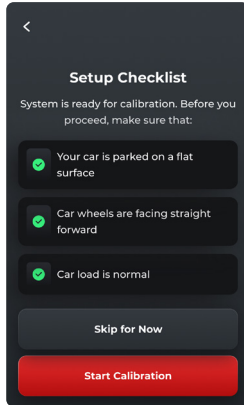

Query before the calibration process starts:

- Vehicle is on level ground
- Wheels are in straight-ahead position
- Vehicle is not loaded

If these requirements are met, the calibration can be started.

This point can be skipped. → Continue to point 9!

However, automatic altitude and pressure control is not possible in this case. Of course, calibration can still be performed at a later time via the settings.

7

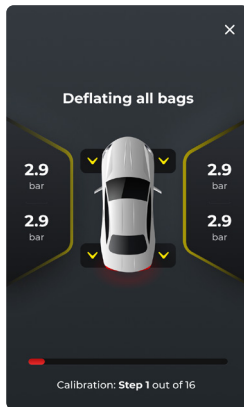

The calibration of the STREETEC autoreleveling goes through 20 steps in which the vehicle moves.

The vehicle must not be moved or loaded during calibration.



Risk of injury!

Quick Start Guide

8

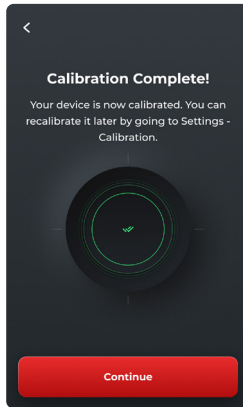

Display when calibration is completed successfully.

9

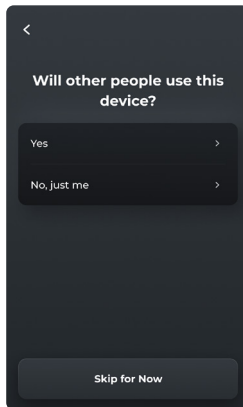

Query whether the vehicle with STREETEC autoleveling is used by different people.

In this case, individual settings and ride heights can be saved for up to 3 people.

This point can be skipped. → Continue to point 11!

Of course, additional users can be added at a later date via the settings.

Quick Start Guide

10

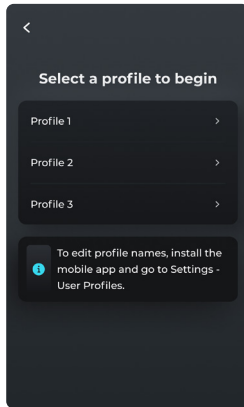

Selecting the first user profile

In the smartphone app, you can also assign names and colors to the profiles!

11

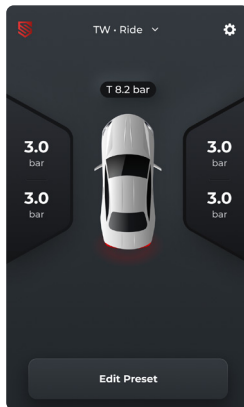

Main screen (without altitude sensors)

- Display after calibration has been completed!

For an explanation of the main screen, see page 60.

Quick Start Guide

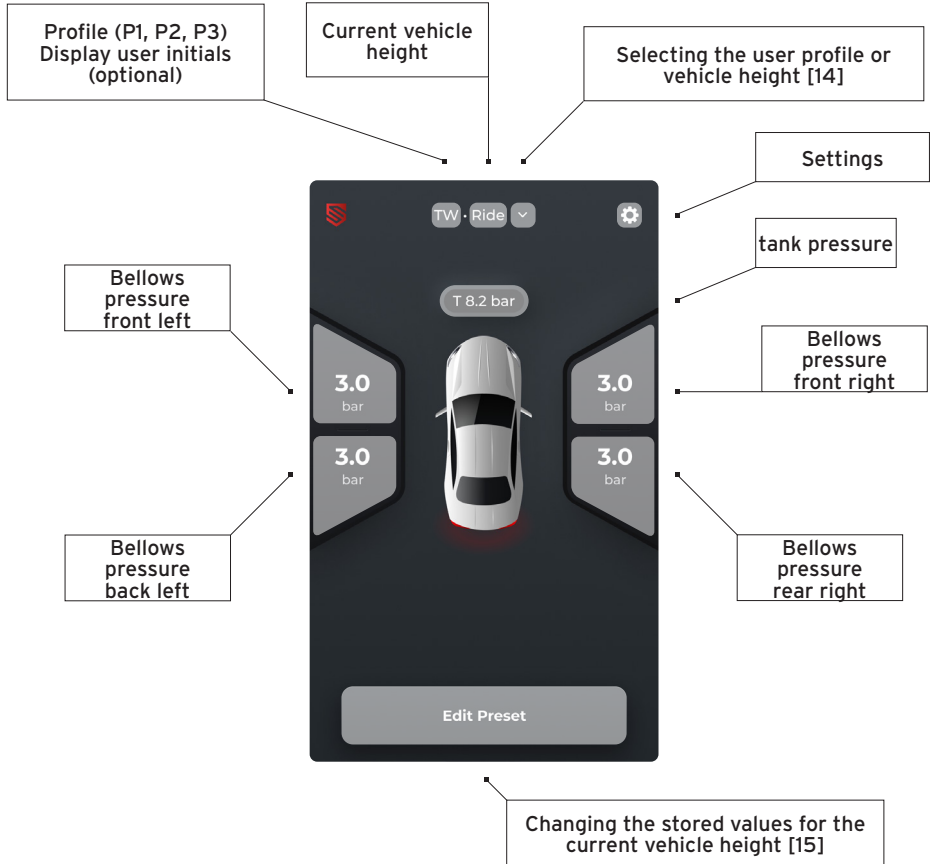

Quick Start Guide

13

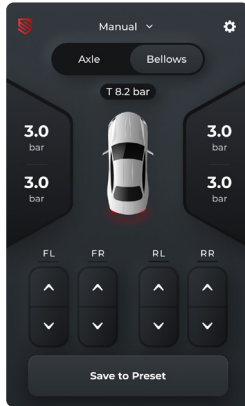

Main screen

- Display if calibration was NOT performed!

14

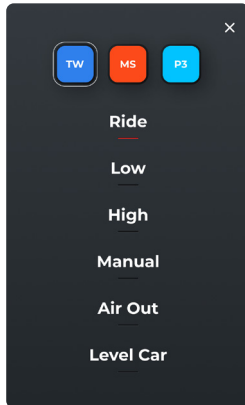

Selecting the user profile

- Examples: TW, MS and P3

Selection of vehicle height

- Ride → normal ride height
- Low → low ride height
- High → high ride height
- manual → manual adjustment (19)
- Air Out → complete lowering
- Level Car → Leveling (20)

Quick Start Guide

15

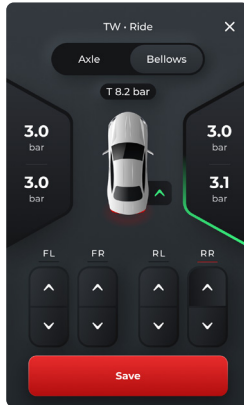

Setting a new driving pressure (without height sensors)

- Adjustment for each wheel position → convertible to axis-by-axis adjustment (16)

16

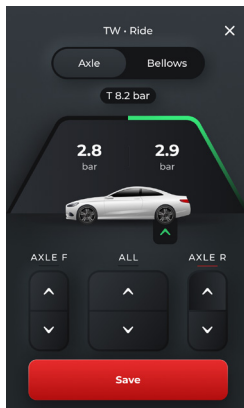

Setting a new driving pressure (without height sensors)

- Adjustment by axle or for the entire vehicle
- adjustable to adjustment for each wheel position separately (15)

Quick Start Guide

17

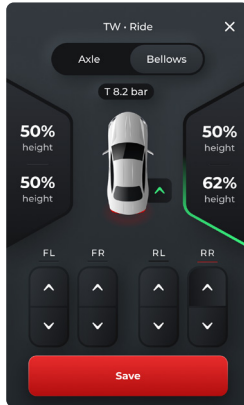

Setting a new ride height (with height sensors)

- Adjustment for each wheel position
- adjustable to axis-by-axis adjustment (18)

18

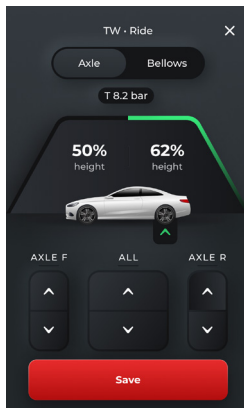

Setting a new ride height (with height sensors)

- Adjustment by axle or for the entire vehicle
- adjustable to adjustment for each wheel position separately (17)

Quick Start Guide

19

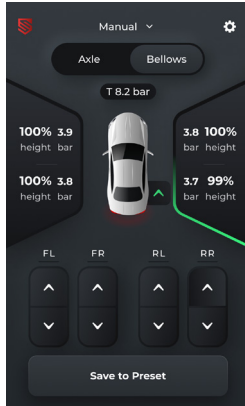

Manual adjustment with display of pressure and altitude (with altitude sensors)

20

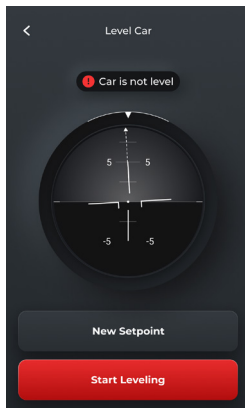

Leveling the vehicle

New Setpoint

- A new reference point can be programmed here. For example, in a motorhome with the bed in an upright position.

Start Leveling

- If a reference point has already been programmed, leveling can be started. The vehicle will then be aligned so that, for example, the aforementioned bed remains level even on uneven ground.

Quick Start Guide

21

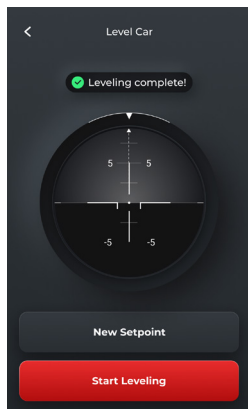

Display after aligning the vehicle.

Settings

For better clarity, the settings are divided into three screens: Basic Settings, Installer Settings, and Expert Settings. This division corresponds to the recommended expertise required for adjusting the available settings.



Do not change any settings whose function you do not fully understand!



An explanation of the settings is available by tapping the blue information symbol “i” on the touchscreen.

Within each screen, the settings are organized into function groups. Some of these function groups are present on multiple screens, but contain different setting options depending on the user groups. The following provides an overview of the function groups and their settings on the respective screens.

Basic settings

GENERALLY

Show mode

When active, the system remains on either for the next ignition cycle or permanently. CAUTION: This will drain the battery.

CONTROL

Rise on Start

When active, the system restores the last selected preset on the next ignition cycle. If the last selected mode was "Air Out," the system restores the "Ride" preset.

CRUISE SAFE

Cruise Safe

Enables (or disables) all safety-related functions. If disabled, all functions managed under "Cruise Safe" are disabled.

DISPLAY

brightness

The brightness of the display in percent.

Basic settings

Quick access

Provides the ability to add up to four predefined quick access actions to the main screen.

lock screen

When active, the system displays a lock screen after 30 seconds of inactivity. Double-tap the screen to unlock it.

PIN REQUEST

PIN options

Offers the option of PIN-locking the HMI. This prevents unauthorized access to your STREETEC autoleveling system.

Installer settings

GENERALLY

pressure unit

The system displays the pressure in the selected unit. Since you're dealing with an EU system, all calculations are performed in bar in the background.

Language

The system displays the text in the selected language.

User profiles

When enabled, the system saves presets and specific settings for each user profile. Use the mobile app to customize the profile initials and color.

Follow-up time

The system remains on for the desired time after the ignition is turned off.

COMPRESSOR CONTROL

Maximum tank pressure

The maximum pressure in the tank. The system does not allow the pressure to rise above this value.

Switch-on threshold

The pressure deviation from the maximum tank pressure at which the compressor is switched on.

Installer settings

Min. battery voltage

The minimum battery voltage at which the compressor is switched off.

Manual tank filling

Offers the possibility to start the compressor even if the pressure is not below the switch-on threshold.

CONTROL

Pressure overrun

When control starts, the system overshoots the setpoint to ensure the vehicle reaches the desired altitude faster and more accurately. This is only recommended for pressure-based systems.

Control accuracy

The control accuracy determines how precisely the system controls the vehicle height. Higher values result in more precise control, but also increase the control time.

Altitude stabilization

When active, the system maintains the selected preset if no vehicle movement is detected for 15 consecutive seconds. Applicable only for altitude-based systems.

Installer settings

drainage

Active drainage

When active, the system drains the water from the tank using a separate drain valve every X minutes of compressor run time, where X is the compressor run time setting.

CRUISE SAFE

Low pressure alarm

When active, the system triggers an alarm if the minimum pressure on an axle is below the set value.

Overpressure alarm

When active, the system triggers an alarm if the maximum pressure on an axle exceeds the set value.

DISPLAY

Dimming by signal

When active, the system dims the display when the signal is active. Requires a connected light signal.

Installer settings

Brightness when darkened

The display brightness when the display is dimmed.

Intensity of haptic feedback

The system provides haptic feedback with the selected intensity.

Vehicle color

The system displays the selected color on the automatic and manual screens. Due to the limited color palette, the color may not be displayed accurately.

Vehicle type

The vehicle type. The system displays the selected vehicle type on the automatic and manual screens.

SENSOR TOOL

Sensor values

Display of the currently measured raw values of the connected sensors.

Altitude sensor tool

Tool for manual adjustment under the display of the current values of the height sensors.

Installer settings

CALIBRATION

Position calibration

Starts the system calibration wizard.

Calibrate speed

Starts the speed signal calibration wizard.

RESET

Reset settings

Resets most settings to factory defaults, but retains information about presets, leveling, and calibration.

Expert settings

COMPRESSOR CONTROL

Duty Cycle

The compressor duty cycle. The compressor is turned on for this percentage of the time. The interval for this period is determined by the compressor runtime setting.

Compressor running time

The compressor reference runtime. The compressor is turned on for the percentage of time determined by the compressor duty cycle setting.

CONTROL

Axle-wise pressure equalization

This only applies to height-based systems. When active, the system first adjusts to the desired height. Then it equalizes the pressure between the left and right sides of the vehicle. This results in a better driving experience.

Axis-wise control

When active, the system only allows axle-by-axle control in manual mode.

drainage

Compressor running time

The drain time. The system drains the water from the tank every X minutes of compressor run time, where X is the compressor run time setting.

Expert settings

CRUISE SAFE

Lock adjustment using acceleration sensor

Offers the possibility to prevent the air suspension from being adjusted while driving using the integrated acceleration sensor.

Lock adjustment by speed signal

Offers the possibility to prevent the air suspension from being adjusted by the speed signal.

Speed threshold for blocking

The speed at which the system should lock.

Locking by handbrake signal

Offers the possibility to prevent the air suspension from being adjusted by the handbrake signal.

Speed Limit Preset Low / High / Manual / Leveling

The speed limit for the selected mode. If the set speed is exceeded, the system automatically switches to "Ride" mode.

Display offset

When active, the system displays the pressures on each axis with the set offset. The minimum displayed value is 0.0 bar / 0 PSI.

Expert settings

Front axle / rear axle limiter value

The limit value of the corresponding axis. The system avoids going below this value on the respective axis.

DISPLAY

Calibrate touch

Offers the possibility to calibrate the HMI touchscreen.

Touch Filter Level

The touch filter level. The system filters touch input with the selected level. Use this setting if you notice that the touchscreen registers touches without your intention.

Start delay

The display is delayed for the set time after the ignition is switched on.

RESET

Factory settings

Resets all settings, presets, leveling and calibration values to the factory defaults.

Firmware update

The firmware update must be carried out via the STREETEC autoleveling app.

Requirements

- Your mobile device is connected to your STREETEC autoleveling control
- You have a stable internet connection, ideally a Wi-Fi network and the corresponding access data
- Your vehicle is parked safely

Implementation

1. Turn on the ignition to start your STREETEC autoleveling.
2. Start the STREETEC autoleveling app on your mobile device.
3. Scan and connect to your controller.
4. Wait until the app has requested the settings and you can navigate to the settings in the app (“gear” button in the top right corner).
5. Select the “Update” option.
6. You'll now see the serial numbers, hardware versions, and current firmware versions of your devices. Click "Check for Updates."
7. After a short server query, another information display appears with the versions available online, as well as two buttons “Update” and “Start Update (old)”.
 - **Update** This is the current update method. You must enter the network name (SSID) and password of a Wi-Fi router within range. After tapping "Start Update," this information is transferred to your ECU. It then terminates the Bluetooth connection to focus all resources on the update process.
 - **Start Update (old)** This is an outdated updating method and should only be used in exceptional cases. Your mobile phone first downloads the update completely from the server. The ECU then launches a Wi-Fi hotspot to which your mobile phone must connect. The HMI must also establish a connection to this hotspot—which often fails due to limited range—which is why this method has been deprecated. The ECU and HMI then use this Wi-Fi hotspot to download the update from your mobile device.

Guarantee

The STREETEC autoleveling control is subject to the applicable warranty conditions. The warranty is void in the event of improper installation, improper use, tampering, or unauthorized modifications to the device. Damage caused by external influences, improper wiring, or unauthorized components is also excluded from the warranty. Further details can be found in the official warranty conditions.

Declaration of conformity

The STREETEC autoleveling meets the essential requirements of the European and national Radio Equipment Directive - 2014/53/EU

The product has been tested according to harmonized standards and is CE marked accordingly.



Conformity has been demonstrated. The relevant declarations and documentation are deposited with the manufacturer.

Disposal instructions



Disposal instructions!

Do not dispose of the device with household waste! Electronic devices must be disposed of at local collection points for waste electronic equipment in accordance with the Waste Electrical and Electronic Equipment Directive.

Manufacturer information

STREETEC GmbH
Industriestraße 12
64739 Höchst im Odenwald

A copy of the manual can also be downloaded from our website:
<https://www.STREETEC.net/ auto-leveling>



Do you need help?

Please contact us from Monday to Friday at +49 (0) 6163 - 939928
to STREETEC's customer service department.



+49 (0) 06 163 939928



info@streetec.net



www.streetec.net



STREETEC GmbH

Industriestraße 12

D-64739 Höchst im Odenwald